

# AMERICAN AVK RESILIENT SEATED GATE VALVE, 250 PSI

66/EEN

Meets AWWA C515 where applicable (NRS)

PEXPE

- DIPS & IPS Polyethylene Pipe Ends - Valve Sizes 2" through 12"

### Use:

For water and neutral liquids to maximum 160°F.

### Tests:

Hydraulic test to AWWA C515:

Shell Test: 500 PSI

Seat Test: 250 PSI

Operating Torque Test

### Optional Materials:

Stem Bronze

Anti Friction Washers Polyamide - W/ Bronze stem only

Bolts Stainless Steel - 316

Pipe 2"- 3"  
SDR 9, SDR 11, SDR 13.5, SDR 17  
4"-12"  
SDR 9, SDR 11, SDR 13.5  
DIPS or IPS. Suitable for butt fusion  
or electro fusion joining. Pipe stubs  
to AWWA C906.  
**Specify IPS or DIPS, and  
SDR when placing order.**

### Standard Materials:

Body, Gland Flange Ductile iron ASTM A536  
Bonnet

Coating Electrostatically applied fusion-  
bonded epoxy-resin

Wrench Nut Ductile iron ASTM A536  
- painted black for open left,  
red for open right.

Stem Standard: Stainless steel ASTM A582

Wedge Ductile iron ASTM A536 encapsulated  
with EPDM-rubber compound

Wedge Nut,  
Thrust Collar Bronze

Bolts Stainless Steel -304 sealed with  
hot melt

Bonnet Gasket,  
Wiper Ring,  
O-Ring Stem Seals,  
O-Ring Gland Seal ASTM D2000 Buna "N" nitrile  
rubber

Pipe PE 3408 or PE 4710. Suitable for butt  
fusion or electro fusion joining. Pipe  
stubs to AWWA C906

### Approvals:

Certified to:  
ANSI/NSF 61, ANSI/NSF 372

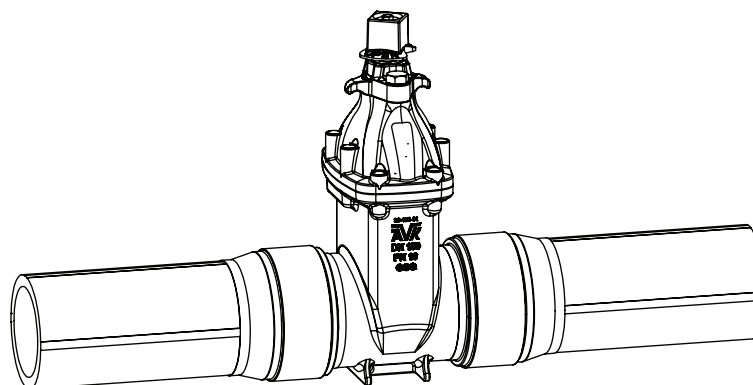

**AMERICAN AVK RESILIENT SEATED GATE VALVE, 250 PSI**  
**Meets AWWA C515 where applicable (NRS)**  
**- DIPS & IPS Polyethylene Pipe Ends - Valve Sizes 2" through 12"**

**66/EEN**  
**PEXPE**

**Component List:**

- |                    |                              |                             |
|--------------------|------------------------------|-----------------------------|
| 217. Bonnet        | 227. Gland Flange Bolt       | 232. Lower Stem Seal O-Ring |
| 218. Bonnet Gasket | 228. Gland Flange            | 233. NRS Stem               |
| 219. Body          | 229. Gland O-Ring            | 234. Thrust Collar          |
| 225. Wrench Nut    | 230. Upper Stem Seal O-Rings | 237. Wedge                  |
| 226. Wiper Ring    | 231. Stem Seal Bushing       |                             |

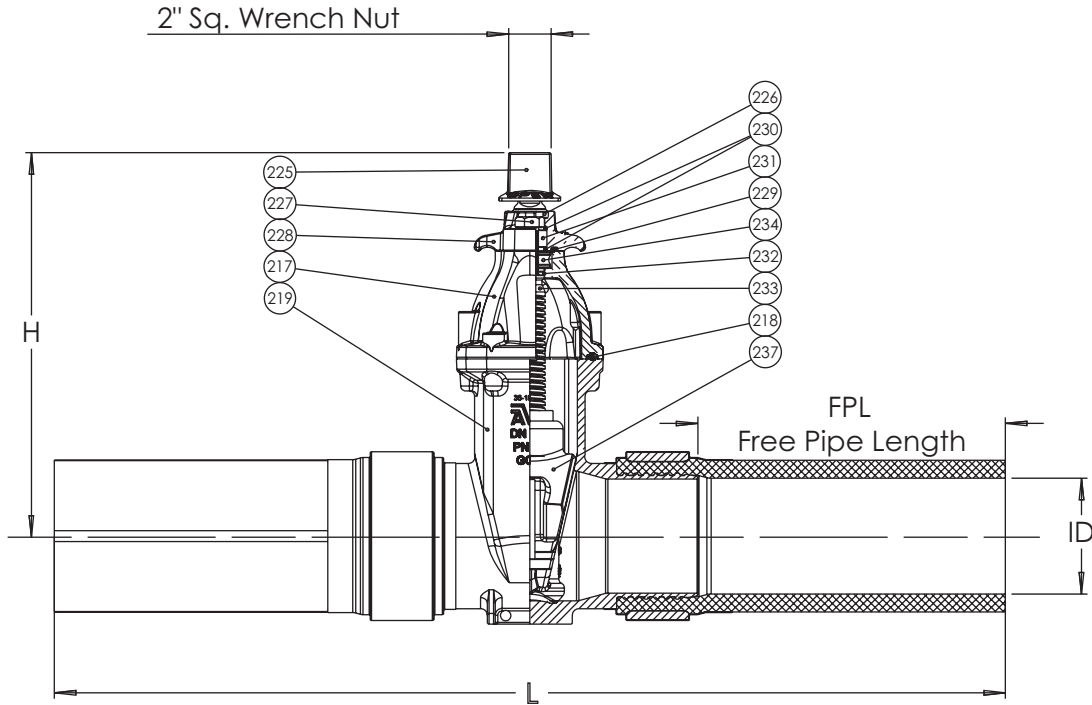

Ref. nos.	Size	H	L	FPL Free Pipe Length	Turns to open	Wt. Lbs.
66-050-EEN	2"	10.50"	19.50"	5.10"	11	20
66-080-EEN	3"	12.09"	19.75"	5.20"	12	36
66-100-EEN	4"	13.50"	41.93"	14.92"	14	56
66-150-EEN	6"	17.50"	43.35"	14.00"	21	114
66-200-EEN	8"	21.50"	44.06"	13.04"	26	175
66-250-EEN	10"	24.75"	44.96"	11.25"	32	227
66-300-EEN	12"	27.63"	47.09"	11.14"	38	335

ID\*: Refer to Pipe Manufacturers reference tables

