

**AMERICAN AVK RESILIENT SEATED DUCTILE IRON GATE VALVE**  
**250 PSI, Tested to AWWA C509 / C515 (NRS)**  
**Mechanical Joint Ends - Valve Sizes 3" - 16"**

**45/MMN-UL**  
**MJxMJ**

**Use:**

For water and neutral liquids to maximum 160°F.

**Tests:**

Hydraulic test to AWWA C509:

Shell Test: 500 PSI 3"-16"

Seat Test: 250 PSI 3"-16"

Operating Torque Test

**Optional Materials:**

Stem For UL, FM, ULC for 3" - 12"  
 Low Zinc Bronze ASTM B763

For UL, FM, ULC for 14" - 16"  
 Aluminum Bronze ASTM B150/B150M

Anti Friction Washers Polyamide

Wedge Ductile iron ASTM A536  
 encapsulated with NBR-rubber  
 compound

**Standard Materials:**

Body, Bonnet, Gland Flange, Wrench Nut Ductile iron ASTM A536  
 (Wrench Nut-painted black for open left, red for open right)

Coating Electrostatically applied fusion-bonded epoxy-resin  
 Meets or exceeds AWWA C550

Stem Standard: Stainless steel - 304

Wedge Ductile iron ASTM A536  
 encapsulated with EPDM-rubber  
 compound

Wedge Nut, Thrust Collar Bronze

Bonnet Bolts Stainless Steel - 316 sealed with hot melt

Gland Bolts Stainless Steel - 316  
 Hexagon bolt

Bonnet Gasket, Wiper Ring, O-Ring Stem Seals, O-Ring Gland Seal  
 ASTM D2000 Buna "N" nitrile rubber

**Approvals:**



\*UL/ULC Listed  
 \*FM Approved  
 Certified to: ANSI/NSF 61, ANSI/NSF 372

Certified to NSF/ANSI 61

Certified to NSF/ANSI 372

\* Approved at 250 PSI working pressure, 3"-12"  
 \* Approved at 200 PSI working pressure, 14"-16"

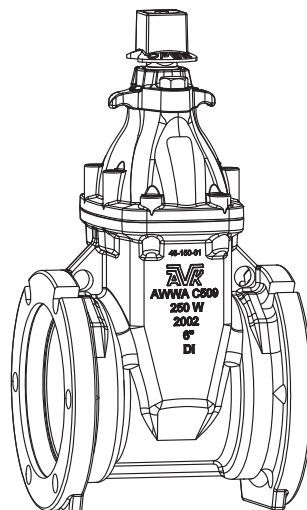

**AMERICAN AVK RESILIENT SEATED DUCTILE IRON GATE VALVE**  
**250 PSI, Tested to AWWA C509 / C515 (NRS)**  
**Mechanical Joint End - Valve Sizes 3" - 16"**

**45/MMN-UL**  
**MJxMJ**

**Component List:**

- |                    |                              |                             |
|--------------------|------------------------------|-----------------------------|
| 217. Bonnet        | 227. Gland Flange Bolt       | 232. Lower Stem Seal O-Ring |
| 218. Bonnet Gasket | 228. Gland Flange            | 233. NRS Stem               |
| 219. Body          | 229. Gland O-Ring            | 234. Thrust Collar          |
| 225. Wrench Nut    | 230. Upper Stem Seal O-Rings | 237. Wedge                  |
| 226. Wiper Ring    | 231. Stem Seal Bushing       |                             |

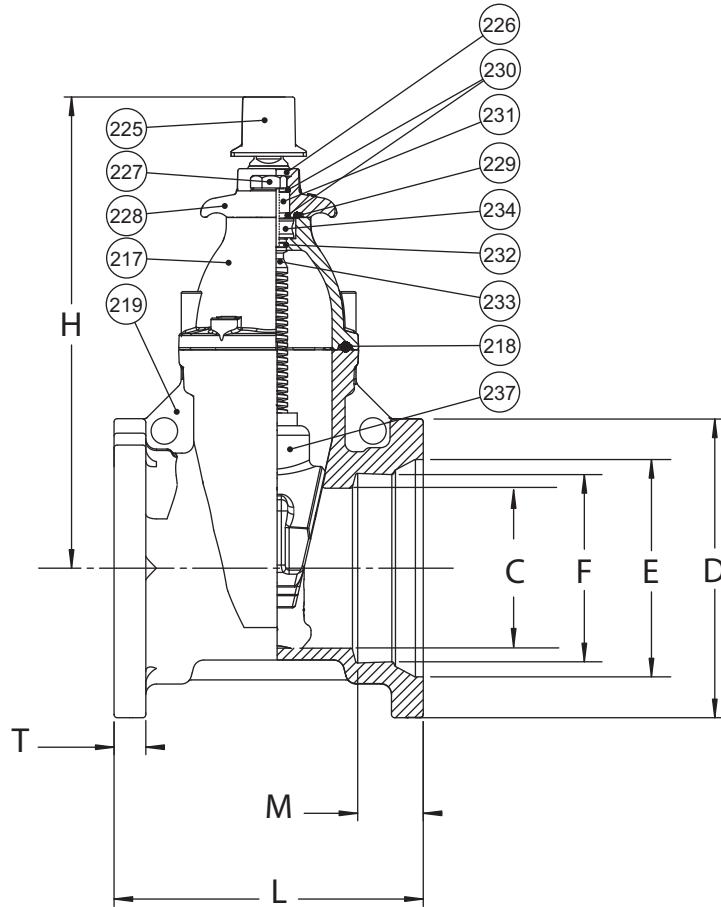

Ref No.	Size	C	D	E	F	H	L	M	T	Turns to Open	Weight (lbs.)
45-080-MMN	3"	3.25"	7.69"	4.96"	4.07"	12.09"	8.50"	2.50"	0.95"	12	43
45-100-MMN	4"	4.25"	9.12"	6.00"	4.90"	13.50"	10.00"	2.50"	1.00"	14	62
45-150-MMN	6"	6.25"	11.12"	8.12"	7.00"	17.50"	11.50"	2.50"	1.18"	21	103
45-200-MMN	8"	8.25"	13.37"	10.27"	9.15"	21.50"	11.50"	2.50"	1.24"	26	155
45-250-MMN	10"	10.25"	15.69"	12.34"	11.20"	24.75"	13.00"	2.50"	1.14"	32	240
45-300-MMN	12"	12.25"	17.88"	14.44"	13.30"	27.63"	14.00"	2.50"	1.22"	38	337
45-350-MMN	14"	14.25"	20.31"	16.61"	15.50"	35.75"	17.95"	3.50"	1.32"	51	794
45-400-MMN	16"	16.25"	22.56"	18.64"	16.12"	34.75"	18.00"	3.50"	1.34"	51	800

