

**AMERICAN AVK RESILIENT SEATED DUCTILE IRON GATE VALVE**  
**250 PSI, Tested to AWWA C509 (OS&Y)**  
**ASME B16.42 Class 150 Flanged x Flanged Ends - Valve Sizes 2 1/2" - 16"**

**45/FFO-UL**  
**FLxFL**

**Use:**  
 For water and neutral liquids to maximum 160°F.

**Tests:**  
 Hydraulic test to AWWA C509:  
 Shell Test: 500 PSI  
 Seat Test: 250 PSI  
 Operating Torque Test





**Optional Materials:**

Wedge	Ductile iron ASTM A536 encapsulated with NBR-rubber compound
-------	--

**Standard Materials:**

Body, Bonnet, Yoke, Gland Follower	Ductile iron ASTM A536
Handwheel	Cast iron ASTM A126 class B
Coating	Electrostatically applied fusion-bonded epoxy-resin Meets or exceeds AWWA C550
Stem	2 1/2"-12" 304 Stainless Steel 14"-16" Aluminum Bronze C63020
Anti-Friction Washer, Wedge Nut 2-piece Stem Nut	Bronze
Wedge	Ductile iron ASTM A536 encapsulated with EPDM - rubber compound.
Bonnet Bolts	Stainless Steel - 316 sealed with hot melt
Stud Bolts, Washers, Nuts	Stainless Steel - 316
Bonnet Gasket, O-rings	NBR
Gland, Gland Bushing	Akulon

**Approvals:**

*UL/ULC Listed	   
*FM Approved	
Certified to: ANSI/NSF 61, ANSI/NSF 372	
* Approved at 250 PSI working pressure, 2.5"-12"	
* Approved at 200 PSI working pressure, 14"-16"	

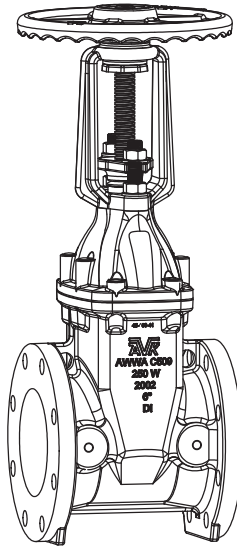

**AMERICAN AVK RESILIENT SEATED DUCTILE IRON GATE VALVE**  
**250 PSI, Tested to AWWA C509 (OS&Y)**  
**ASME B16.42 Class 150 Flanged x Flanged Ends - Valve Sizes 2 1/2" - 16"**

**45/FFO-UL**  
**FLxFL**

**Component List:**

- |                                 |                           |                               |
|---------------------------------|---------------------------|-------------------------------|
| 201. Upper Stem Nut             | 208. Gland Follower       | 215. OS&Y Stem Assembly       |
| 202. OS&Y Handwheel             | 209. Gland                | 216. Bonnet Bolts (Not Shown) |
| 203. Anti-Friction Washer       | 210. Stud Bolt            | 217. Bonnet                   |
| 204. Yoke                       | 211. Stem Seal O-rings    | 218. Bonnet Gasket            |
| 205. Lower Stem Nut             | 212. Inner Bushing O-ring | 219. Body                     |
| 206. Gland Follower/Yoke Nut    | 213. OS&Y Bushing         |                               |
| 207. Gland Follower/Yoke Washer | 214. Outer Bushing O-ring |                               |

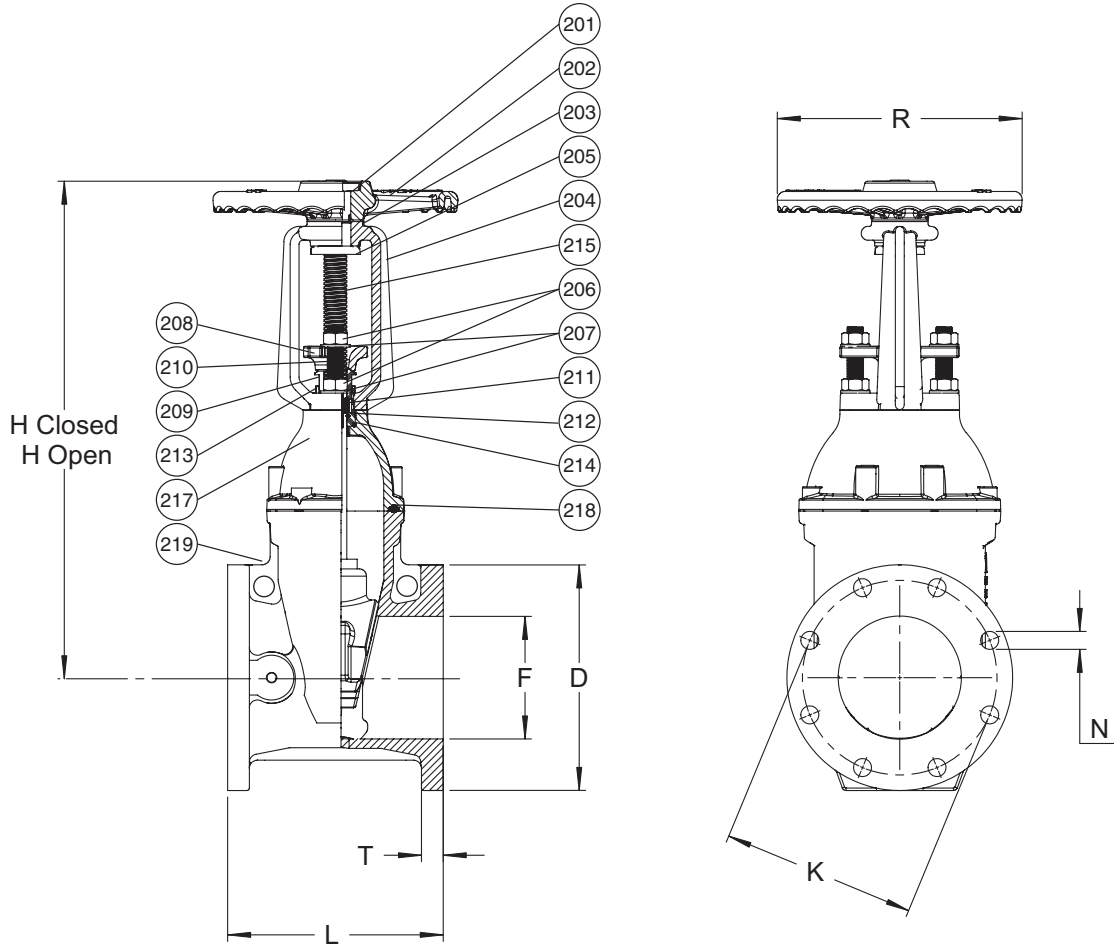

Ref. nos.	Size	D	F	H open	H closed	K	L	N	R	T	Flange holes	Turns to open	Wt. Lbs.
45-065-FFO-UL	2.5"	7.00"	2.50"	17.50"	15.00"	5.50"	7.50"	0.75"	7.00"	0.70"	4	17	42
45-080-FFO-UL	3"	7.50"	3.00"	18.63"	15.63"	6.00"	8.00"	0.75"	7.00"	0.79"	4	20	56
45-100-FFO-UL	4"	9.00"	4.00"	22.63"	18.63"	7.50"	9.00"	0.75"	10.00"	1.00"	8	21	84
45-150-FFO-UL	6"	11.00"	6.00"	31.00"	25.00"	9.50"	10.50"	0.88"	12.00"	1.06"	8	26	138
45-200-FFO-UL	8"	13.50"	8.00"	39.00"	31.00"	11.75"	11.50"	0.88"	14.00"	1.14"	8	35	211
45-250-FFO-UL	10"	16.00"	10.00"	46.80"	36.80"	14.25"	13.00"	1.00"	17.00"	1.22"	12	37	303
45-300-FFO-UL	12"	19.00"	12.00"	53.50"	41.50"	17.00"	14.00"	1.00"	17.00"	1.30"	12	44	431
45-350-FFO-UL	14"	21.00"	14.00"	70.43"	55.24"	18.90"	15.00"	1.14"	25.00"	1.40"	12	50	673
45-400-FFO-UL	16"	23.50"	16.00"	71.00"	54.70"	21.25"	16.00"	1.14"	25.00"	1.44"	16	56	684

